



-L1e Usage Manual

- * Please do read the manual carefully !
- * Do not use the electric motorcycle without knowing its performance !
- * Please properly preserve this Manual .

Contents



iOS
installation code



Android
installation code

- 1.....Safety Instructions
- 2.....Functional Indication
- 3.....Meter Function
- 4.....Spare Parts and Accessories
- 5.....Installation Guide
- 6.....Connect GOWOW App
- 7.....Safe Riding
- 8.....Usage of Battery
- 9.....Precautions for Charging
- 10.....Disclaimer
- 11.....Specification
- 12.....Maintenance
- 13.....Troubleshooting
- 14.....DTC List

Thank you for choosing--

The pictures are for reference only; the actual product appearance and functions are subject to the actual product.

- Please install the license plate as required according to local laws and regulations.
- You have an obligation to familiarize yourself with the laws and regulations in your area and comply with relevant laws and traffic rules.
- To make the vehicle better service to you, please do read the manual carefully before riding and carefully check whether all parts are in good condition to ensure your riding safety. If you find any problems, please contact the dealer.
- Please be familiar with the contents of this manual, and then, better to find a training ground to have some trial riding practice. So that you can well master the riding skills and learn more about the structure and performance of this electric vehicle. This will be the base for safe riding. Fully understanding the vehicle's performance, usage, and maintenance methods will enable you to properly ride the vehicle with the best performance, less malfunctions, and longer lifetime.
- To ensure your safety, please wear safety helmets, gloves, and other protective equipment during riding.
- The rated loading capability for this electric vehicle is 1 person. Please do not carry passengers or items.
- This product contains many electrical components, please do not expose to the rain for a long time; please remove the battery when washing the vehicle, and it is strictly forbidden to use a high-pressure water gun to flush the battery or other components.
- Please avoid cycling in heavy rain or water. When the water surface exceeds the center of the wheel, it may affect the work of the motor and brake. When the battery is wet, charging may cause the battery to burn or explode.
- Do not charge or park inside buildings. When charging, keep away from flammable materials and avoid overcharging.

- Please drive carefully in complex road conditions. When riding this product over obstacles, uneven ground, slippery roads, steep slopes, or sharp turns, bumps, falls or injuries may occur.
- Please avoid riding in rainy weather or on roads with deep water on the road surface. This product can be driven in rainy and snowy weather, but it cannot be used for a long time to avoid affecting the working life of the battery and motor to ensure safety.
- Do not disassemble or refit parts by yourself. If replacement is required, please contact your local dealer.
- For the safety of others, please do not lend your vehicle.

The following persons are strictly prohibited from riding this product

- Persons under the age of 18.
- Pregnant women or persons with medical conditions that prevent strenuous activity.
- People under the influence of alcohol or drugs.
- Persons whose weight exceeds the limit (refer to P20 ~ P21 "Specification").

2 Functional Indication

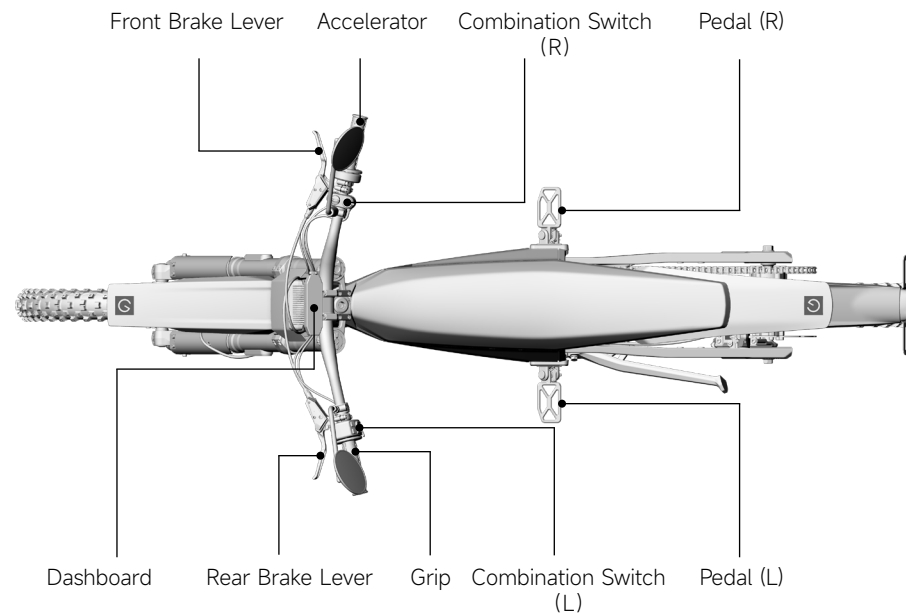

* The pictures are for reference only, please refer to the actual product for appearance and function.

- ⓘ When the temperature of the motor and controller is too high, or the battery is too low, the vehicle will run with power reduction automatically. That is not a fault.

Right Side View

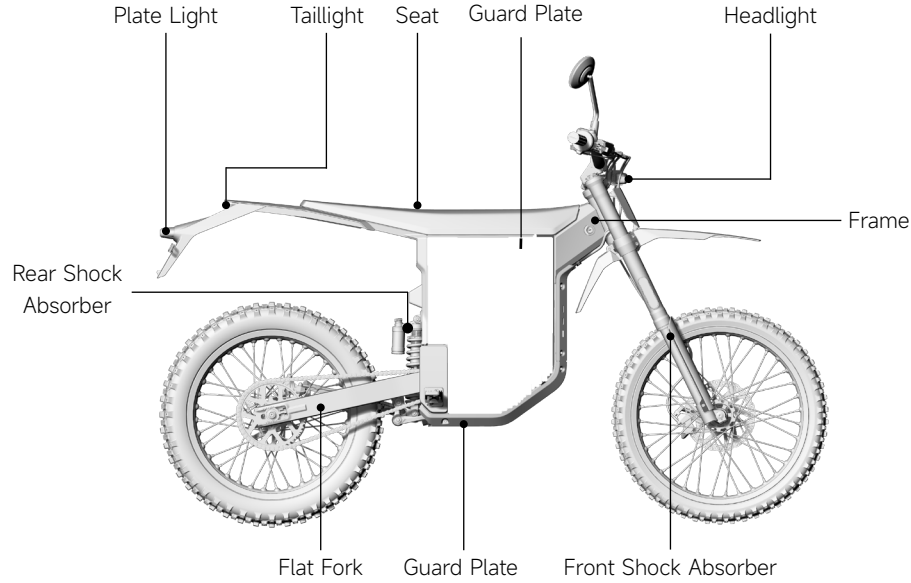

* The pictures are for reference only, please refer to the actual product for appearance and function.

- ⓘ When the temperature of the motor and controller is too high, or the battery is too low, the vehicle will run with power reduction automatically. That is not a fault.

Left Side View

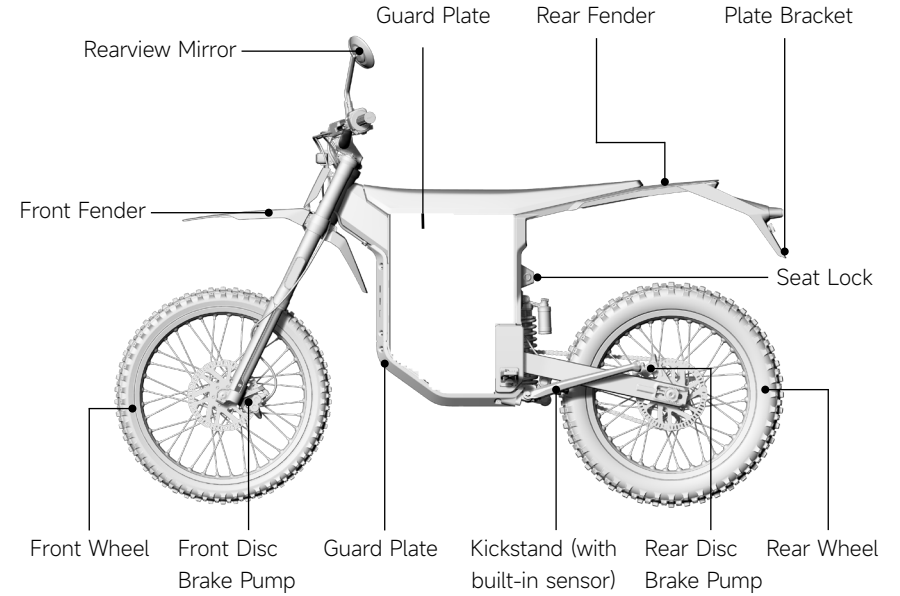

When the kickstand is put down, the motor will not start when you rotate the accelerator

* The pictures are for reference only, please refer to the actual product for appearance and function.

- ⓘ When the temperature of the motor and controller is too high, or the battery is too low, the vehicle will run with power reduction automatically. That is not a fault.

Combination Switch

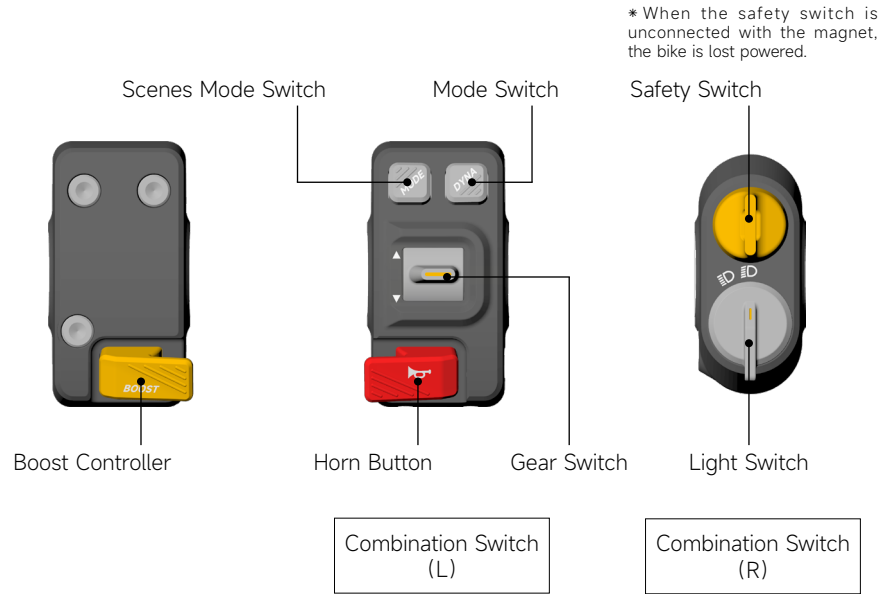

3 Meter Function

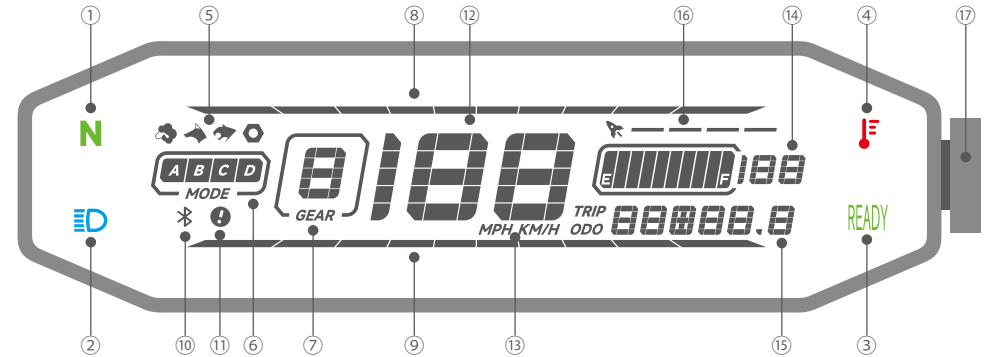

- | | | |
|---------------------------|--------------------------------------|--|
| ① N gear indication | ⑦ Gear indication | ⑬ KM/hour display |
| ② High beam warning light | ⑧ Discharge power indication | ⑭ Battery indicator |
| ③ READY indication | ⑨ Kinetic energy recovery indication | ⑮ ODO Mileage\Single trip distance
Trip distance in total \TIME |
| ④ Overheating indication | ⑩ Bluetooth indication | ⑯ BOOST TIMER |
| ⑤ Power mode | ⑪ Failure indication | ⑰ Meter Button |
| ⑥ Scenes mode | ⑫ Speedometer | |

- * All function indicator lights are on in the working state and off in the non-working state.
- * It is possible to change the unit of measure (from KM to Miles).
- * Meter Button:
HOLD: on/off;
CLICK 1 time: total odometer/partial odometer/ time;
CLICK 2 times: change the unit of measure.

4 Spare Parts and Accessories

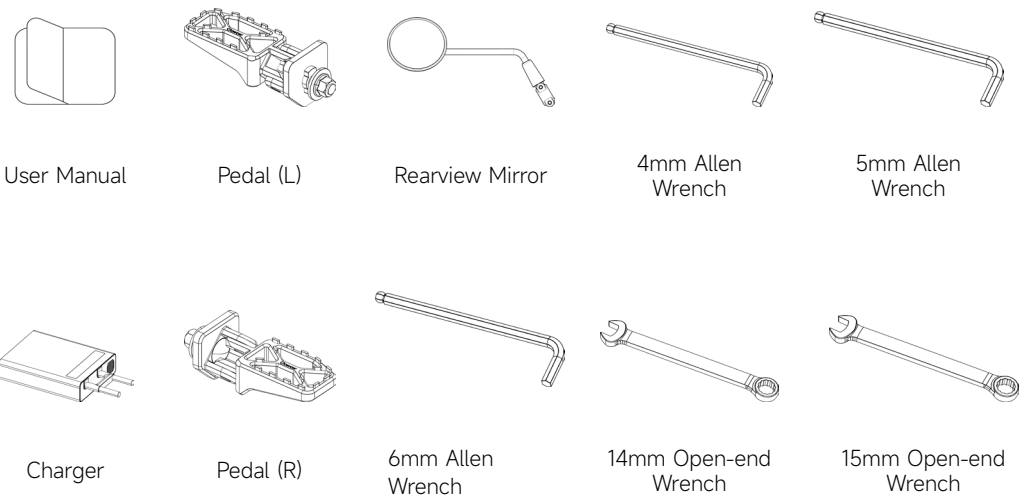

5 Installation Guide

Install the Pedals

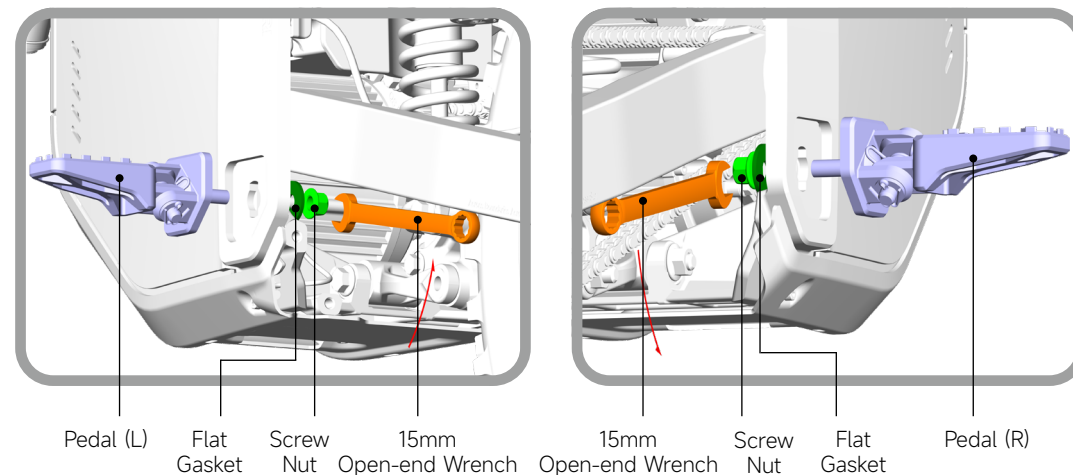

Take out the pedals (L&R) from the packing box, loosen the nuts, put the pedals into the corresponding slots, and then pre-install flat washers and nuts from the inside in sequence, and finally lock the nuts with a 15mm open-ended wrench.

* Recommended tightening torque for pedals: 37 ± 3 Nm.

* Install the pedals before installing the side stand.

Install the kickstand

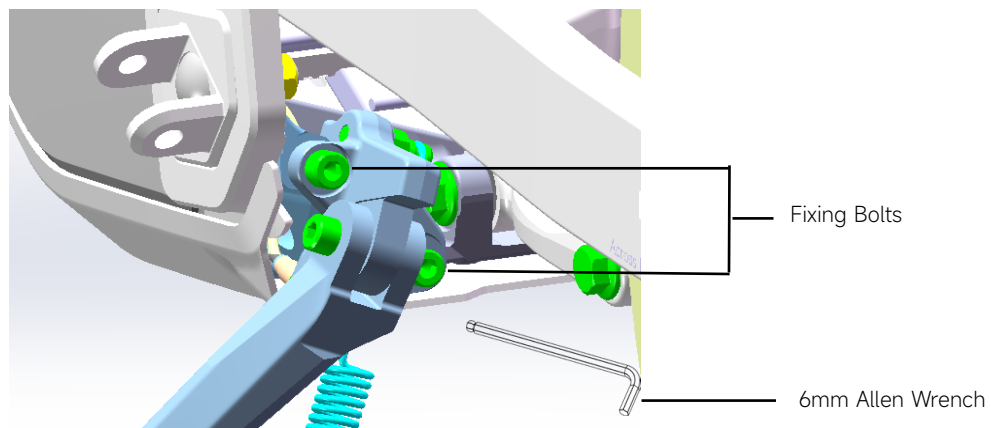

Cut the nylon cable tie from the rear fork, remove the side stand, take out the fixing bolts, and swing the side stand to the position shown in the figure. After the holes correspond, pre-lock it first, and finally fix it with a 6mm Allen Wrench (The fixing bolts are packed in a sealed bag and tied to the kickstand).

- * Because the kickstand contains sensors, the sensor harness has been connected to the bus harness when the product is received, so do not pull it when removing it to avoid damage.
- * When the product is received, the functional structure of the side stand is in the retracted state, please do not directly operate the propped up or retracted state by hand, so as not to cause injury.
- * Recommended tightening torque for temple: 20 ± 3 Nm.

Install the handlebar

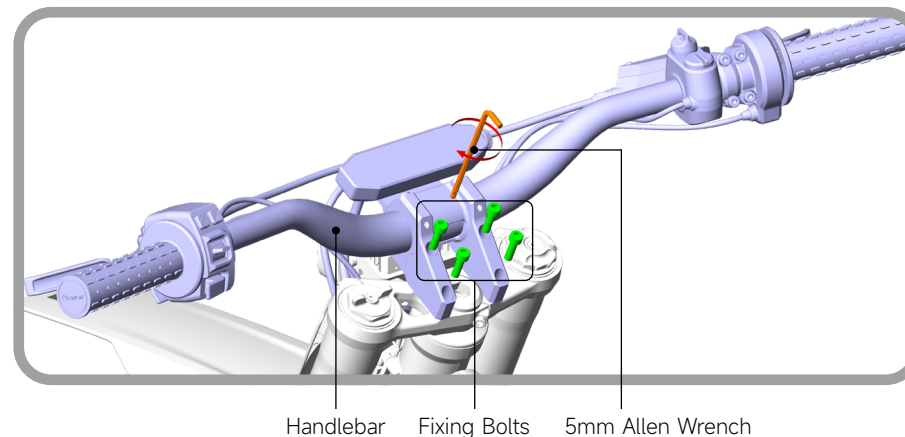

The handlebar is fixed on the rear side of the front fork by a nylon cable tie. Cut off the tie, remove the handlebar, take out the fixing bolts, and put the handlebar in the position as the picture shows. After the corresponding hole position, pre-lock it, and use a 5mm L-shaped wrench to lock it up.

- * Recommended tightening torque for handlebar: 14 ± 2 Nm.

Install Rearview Mirror

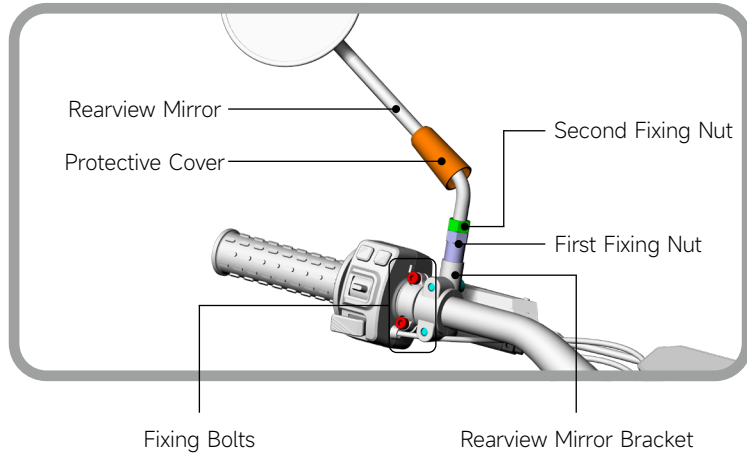

Rearview Mirror Installation Instructions:

1. Use a 4mm Allen wrench to loosen the brake lever to an active state, making space available for operating the wrench to tighten the rearview mirror;
2. Use a 5mm Allen wrench to loosen the (L or R) rearview mirror bracket and adjust it to the appropriate position according to the (L or R) handlebar. Tighten the fixing screw;

3. Adjust the first and second fixing nuts of the rearview mirror to a free and movable state. Use a 14mm open-end wrench to tighten the first fixing nut, which secures the mirror to the bracket. Then adjust the angle of the mirror (turn it left) according to your needs and tighten the second fixing nut as appropriate;
4. Adjust the protective cover to cover the fixing nut;
5. Finally, adjust the brake lever back to its original position and tighten the fixing screw.

6 Connect GOWOW App

User Registration

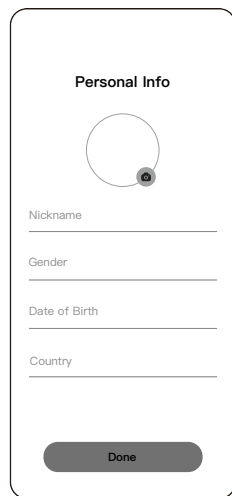
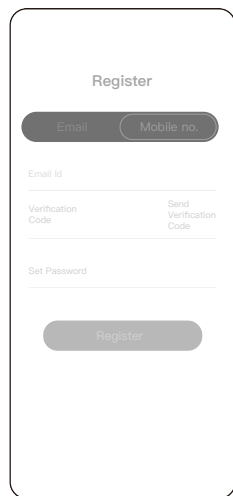
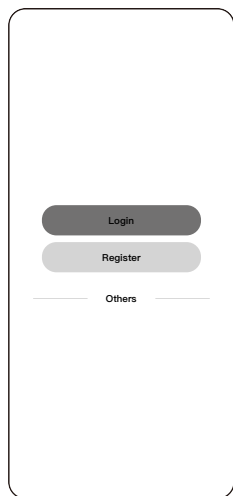

1、Scan the QR Code inside the cover to download and install the GOWOW APP. After the installation is complete, start the APP and enter the user login/ registration page.

2、Click "Email Registration" or "Mobile Number Registration" to enter the registration page and follow the hint to complete registration.

3、After filling in the information, click the Done button.

* GOWOW APP has 2 registration methods, "email registration" and "mobile registration". Users can register according to their actual needs.

Vehicle Binding

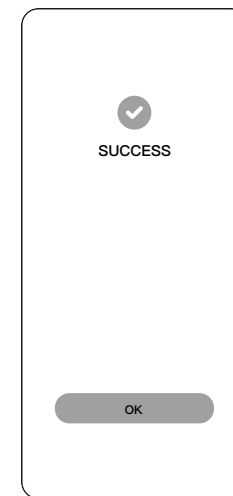
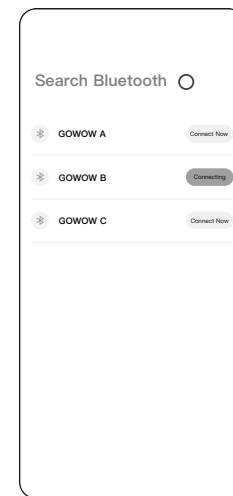
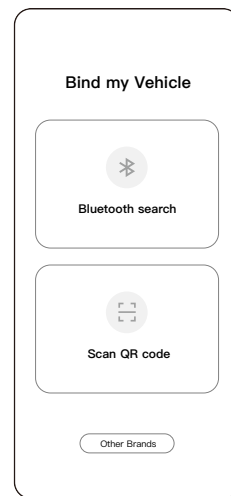

1、Enter the vehicle binding interface and bind my vehicle.

2、On the interface of binding my vehicle, click "Bluetooth Search" or "Scan QR Code", and follow the prompts to bind the vehicle.

3、Click OK to complete the vehicle binding.

* GOWOW APP has two binding methods, namely "Bluetooth Binding" and "Scan QR code". Users can choose any binding method according to their actual needs.

7 Safe Riding

Precautions for Riding

- Check the tire tread depth and any cracks, damage, foreign objects, abnormal wear.
- The normal tire pressure for both front and rear tires are 33psi(225kPa).
- Please check whether the motor screws are loose.
- Please check whether the connection of motor and controller is loose, as well as the status of insulation.
- Please check whether the handlebar and seat are well adjusted and reliably fixed, and the front and rear wheels are stable.
- Check the front and rear brake handlebars to confirm whether the brake function is normal.
- Check battery capacity.
- To ensure your safety, please wear safety helmets, gloves, and other protective equipment during riding.
- Rotate the accelerator inward and outward and check the accelerator whether in its right position.
- Please ride without the above abnormal conditions.

Riding Operations

- Start: Turn on the electric start switch on the right side of the meter (see P9 "Meter Functional Areas of Instruments" 17) and check if the various functions of the meter are normal.
 - Adjust speed: You can rotate the accelerator inward for acceleration and rotate the accelerator outward to deceleration.
 - Brake: Reset the speed accelerator quickly, hold the left and right brake handles with appropriate force.
- ⓘ Please control the force on brake handles accord to the actual situation, gradually increase the force, and do not suddenly hold the brake handles to be too tight. Otherwise, may cause the wheel-lock and tire-slip, and bring dangers.

Parking Method

- Please turn off the electric start switch immediately after getting off the vehicle. please DO NOT park the vehicle on the inclined ground or soft ground to prevent the vehicle dumping.
- Do not park in no-parking areas, such as evacuation stairs, fire exits or emergency exits.
- It is recommended to store the battery separately after riding.

8 Usage of Battery

This product uses a lithium battery, please strictly abide by the regulations when using it, and the loss and injury caused by wrong use have nothing to do with this product.

Battery Usage Environment

- Discharge temperature range is from: $-20^{\circ}\text{C} \sim 60^{\circ}\text{C}$
- The charging temperature range is from: $0^{\circ}\text{C} \sim 45^{\circ}\text{C}$

Safety Regulations & Caution

- It is forbidden to use in an environment that exceeds the waterproof level of the shell, and the internal waterproof of the battery may fail under changes in environmental conditions and usage conditions.
- Do not immerse the battery in liquids such as water, beverages or other.

- Do not use or leave the battery near fire, heater or high temperature environment.
- Only original charger can be used in charging.
- Do not use the battery in other devices or equipment.
- Do not incinerate or heat batteries.
- It is forbidden to use metal objects such as wires to directly connect the positive and negative of the battery to short-circuit the battery.
- Prohibit excessive mechanical impact on the battery, such as bumping, throwing, trampling, etc.
- Do not pierce the battery with nails or other sharp objects.
- Do not disassemble the battery.
- If the vehicle is not used for a long time, please charge it every 3 months.

9 Precautions for Charging

- Please DO NOT use any other types of chargers to charge the battery, to prevent any damages of battery or dangers.
- While charging, please place the charging device in a safe place where children are not accessible.
- When charging, please carry out in a dry and well-ventilated environment.
- It is not allowed to cover the charger with any objects while charging.
- When an odor or high temperature occurs during the charging, or the battery cannot be fully charged for a long time, please stop charging immediately, and sent the charger and battery to the after-sales service center to do inspection.

10 Disclaimer

- The descriptions and images in this publication are given for illustrative purposes only and are not binding, While the basic specifications as described and illustrated in this manual remain unchanged, GOWOW reserves the rights, at any time and without being required, to update this publication beforehand, to make any changes to components, parts or accessories, which it considers necessary to improve the product or which are required for manufacturing or construction reasons.
- To the extent permitted by law, GOWOW reserves the right to interpret and explain this statement.
- This statement applies to users worldwide. GOWOW is not liable for all claims, responsibilities and losses caused or possibly caused by consumers' violation of the above statement. Unforeseen or unavoidable risks encountered during riding shall be borne by the driver himself.
- This booklet forms an integral part of the vehicle; should the vehicle be sold; it must be transferred to the new owner.

11 Specifications

	Item	Alpha
Basic Information	Length × Width × Height	1910mm x 780mm x 1100mm
	Vehicle Weight/ Including Battery	74kg
	Battery Weight	16kg
	Max.Load	100kg
	Rider Age	18-55 yrs
Vehicle Parameters	Wheelbase	1275mm
	Minimum Clearance	280mm
	Seat Height	890mm
	Range	75km
	IP Rating	IP65
Battery	Charging Time	2.6h
	Capacity	29.4Ah
	Rated Voltage	72V
Other Parameters	Front Wheel	70/100-19 TT MX
	Rear Wheel	3.50-18 TT MX
	Secondary Drive System	428H

- The cruising range is the distance traveled by the vehicle on a full charge, and the cruising range will vary slightly according to the actual rider's weight, ambient temperature, riding speed and road conditions.
 - The cruising range here is measured when the rider weighs 75kg, the ambient temperature is 25° C, and the rider rides at a constant speed of 25km/h.
 - Factors that affect your mileage include: riding speed, number of starts, acceleration, ambient air temperature, altitude change, tire pressure, tire type and load, etc.
- * Due to the continuous improvement of the product, the performance parameters are subject to change without prior notice.

12 Maintenance

To protect the service life of your ORI, it is recommended that you check and maintain it regularly. Pay full attention to safety during maintenance, and park the vehicle in a wide and flat place for checking.

In principle, it is recommended to do the first inspection and maintenance at 300km for normal riding.

Check Contents

- Tightness of front and rear wheel wire spokes.
- Whether there is a gap in the steering headset, and whether there is any sticking and loosening.
- Check the tightness of chain.
- Adjust the shock absorber, check whether there is oil leakage, and whether the compression and rebound damping is in the correct position (ⓘdo not turn the adjustment knob to the leftmost or rightmost during the adjusting process).
- Check the tightness of each screw on the handlebar.

Pay full attention to safety when checking

- The vehicle must be powered off, that is, it must not be operated when the vehicle is started during the entire maintenance process.
- Park the vehicle in a wide and flat place.
- Carry out in a safe place and pay attention to the surrounding environment and conditions if riding inspection needed.
- If any abnormality is found after checking, please eliminate the abnormality before riding.If it is difficult to solve it by yourself, please contact after-sales service or designated authorized service network.

Operating parts checking

- Check the shock absorber for bending, deformation, damage

Check the front shock absorber for damage, looseness, oil leakage, etc.Shake the handlebar up and down to check whether there is any abnormal noise caused by the fault of the front shock absorber. If there is any abnormal noise, please contact after-sales service or designated authorized service network.

- Brake checking

Check the break force feedback of the brake handle regularly. Check the break pads and replace the pads in time if serious wear.

- Braking effect checking

Please drive at a low speed on a dry and flat road for checking, and use the front and rear brakes separately to check their respective braking effects.

- Tire checking

Check the tires for foreign objects before riding. Pay attention to the road surface and avoid riding in places that may damage the tires when riding. In addition, check the tires frequently for unreasonable abnormal wear such as obvious cracks.

- 1) Use the tire pressure gauge to check the tire pressure while the tires are under cooling.
- 2) Check for cracks, damage, foreign matter or abnormal wear.
- 3) Check the rim spokes for looseness.
- 4) Check the tension of the chain, which should be 20mm-30mm up and down.
- 5) Tire groove depth checking.

Check the tire wear, check the groove depth, and replace the tire when the wear reaches the wear line of the bump. When the tires have abnormal noises or swings during riding, please contact the after-sales service or designated authorized service network for check and maintenance.

battery check

- Check the appearance of the battery

Whether it is damaged, such as the upper and lower sealing covers of the battery and the indicators are damaged, which will lead to the risk of water ingress after the sealing fails. Please contact after-sales service or designated authorized service outlets.

Brake Fluid Check

- Please ensure that the oil level (brake fluid) is above the marked line.
- Check for obvious bubbles in the brake fluid.

ⓘ If any brake fluid other than the specified Mineral oil is used, the brake may fail, posing a risk of personal injury.

Use and Maintenance of Motor and Controller

- Regularly check the motor screws for looseness.
- Regularly check motor and controller wiring for looseness and insulation.
- Do not ride in too deep water, so as not to affect the motor work.
- Do not overload. When the vehicle cannot start normally due to obstruction, do not start repeatedly, and start after removing the resistance.

Regular maintenance and check

A vehicle inspection is required for accumulative riding of 300km or 3 months.

Maintenance Item	Maintenance Purpose
Brake	Detect brake performance to prevent brake failure during riding.
Tire	Detect tire damage and tire pressure to prevent tire blowout or excessive power consumption during riding.
Hub	Detect the strength of the hub, decontaminate the bearings, and prevent the hub from cracking and jamming.
Shock Absorber	Detect the usage of front and rear shock absorbers, decontaminate and lubricate to prevent shock absorbers from sticking.
Throttle	Detect the throttle to prevent sticking and affect riding.
Lines	Detect whether the line connector is loose or the line is damaged to prevent line fault.
Screw	Detect whether the screws in key parts are firm to prevent them from loosening and falling off.
Chain	Detect whether the chain is too loose to prevent accidents during riding.
Battery	Detect battery cases, prevent line faults, reduce risks and extend life.
Charger	Check whether the charger cable is broken, disconnected or off-line, and whether the input and output plugs are intact and reliable.

13 Troubleshooting

	Problem	Possible Causes	Corresponding Solution
1	Turn on the power and turn the throttle, the motor does not work	<ol style="list-style-type: none"> 1. The battery connection line is loose 2. The safety switch falls off 3. The motor connection wire is loose or falls off 4. The brake handle does not return or the brake switch is faulty 5. The vehicle is equipped with a side stand switch, but the side stand is not retracted 	<ol style="list-style-type: none"> 1. Check whether the connection line is firmly connected 2. Put back the safety switch 3. Maintenance and after-sales service check 4. Check the brake handle and brake switch 5. Retract the side stand
2	Speed regulation failure or low maximum speed	<ol style="list-style-type: none"> 1. The battery power is too low 2. Throttle fault 	<ol style="list-style-type: none"> 1. Fully charge the battery 2. Maintenance and after-sales service check
3	The charger does not charge	<ol style="list-style-type: none"> 1. The charger plug is disconnected or the connection is loose 2. The charger is faulty 	<ol style="list-style-type: none"> 1. Insert the plug or connector tightly 2. Maintenance and after-sales service check
4	Insufficient mileage on a single charge	<ol style="list-style-type: none"> 1. Insufficient tire pressure 2. Insufficient charging or charger fault 3. Improper brake adjustment and excessive riding resistance 4. The battery is aging or damaged 5. Much uphill, headwinds, frequent acceleration and deceleration or heavy loads 	<ol style="list-style-type: none"> 1. Inflate the tire to the proper pressure 2. Fully charged or check the connection of the charger plug 3. Readjust the brake 4. Replace the battery 5. It is normal to reduce mileage under the usage environment

	item	fault reasons	methods
5	Abnormal noise of the bike body during riding	<ol style="list-style-type: none"> 1. The chain tightness is unreasonable 2. The screws are loose 	<ol style="list-style-type: none"> 1. Adjust the tightness of the chain 2. Check whether the screws are loose
7	Other faults	<ol style="list-style-type: none"> 1. When you encounter faults that cannot be eliminated by yourself under the above guidance or faults that cannot be determined 2. The motor, controller, charger and battery are damaged 	If you encounter the above situations, please contact the supplier or maintenance network, Do not open the above parts without authorization, or you will lose our company's warranty commitments

Please read the above that do not belong to free warranty carefully.

14 DTC List

Fault Code Value	Meaning	Solution
8	Throttle not returned	Check whether the throttle is stuck, and clear the fault
4	Motor temperature is too high to affect operating efficiency	Wait for the vehicle to return to normal temperature
5	Controller temperature is too high to affect operating efficiency	
37	Battery discharge over temperature fault	
38	Battery charging over temperature fault	
39	Battery discharge undertemperature fault	
40	Battery charging undertemperature fault	
41	Battery discharge MOS over temperature fault	
42	Battery charging MOS over temperature fault	
43	Battery soft start circuit over temperature fault	
63	Battery charging over temperature	
65	Battery charging undertemperature	
67	Battery charging MOS over temperature	
72	Charger software detects overtemperature	
73	Charger hardware detects overtemperature	
2	Controller temperature sensor disconnected	Please contact after-sales service
3	Motor temperature sensor disconnected	
6	Motor angle sensor disturbed	
7	The signal of the throttle is unstable	
9	The motor rotor is blocked and does not rotate	
10	Controller undervoltage	

Fault code value	Meaning	Solution
11	Controller software overcurrent fault	Please contact after-sales service
12	Motor speed is too high	
13	Controller overvoltage fault	
14	Abnormal power supply	
15	Motor angle sensor disconnected	
16	Controller hardware overcurrent fault	
17	Controller current closed loop fault	
18	Current sensor fault	
19	Battery protection IC error	
20	Battery cell disconnected	
21	Battery cell unbalanced	
25	Battery discharge MOS damaged	
26	Battery charging MOS damaged	
27	Battery overcharge error	
29	Battery secondary over-discharge error	
32	Battery charging overcurrent fault	
33	Battery soft start failed	
34	Battery precharge timeout fault	
35	Battery MOS temperature sensor fault	
36	Battery cell temperature sensor fault	
44	Battery RAM error	
45	Battery discharge insurance damage	

Fault Code Value	Meaning	Solution
46	Battery charging insurance damage	
47	Battery tertiary overcurrent	
48	Battery quaternary overcurrent	
49	Battery configuration error	
58	Battery charging overcurrent warning	
69	Charger software detects output overvoltage	
70	Charger hardware detects output overvoltage	
71	Charger output undervoltage	
74	Charger battery reverse connection	
75	Charger communication fault	
76	Charger input undervoltage	
77	Charger output overcurrent	
78	Charger output relay voltage difference is too large	
79	Charger output short circuit	
80	Charger Timing Protection	
81	Controller communication fault	
82	BMS communication fault	
83	ECU communication fault	

Please contact after-sales service

Warranty Start Date:

- For offline purchase users, the warranty starts from the date of the invoice or the date of the purchase voucher (whichever comes first).
- For online purchase users, the warranty starts from the date of receipt.

Warranty Policy:

- One year comprehensive warranty for the entire vehicle: including the motor, controller, battery, charger, and other non-wearing parts. Performance failures not caused by human damage are eligible for free repairs. If there are no quality issues, returns or exchanges are not supported.
- In case of functional failures or product quality issues, upon inspection by GOWOW designated authorized service centers to confirm that they are not caused by human factors, customers can choose between a return or an exchange.



Vehicle SN Code

Due to technology upgrades and firmware updates, the actual product appearance and functions are not completely consistent with the content of the manual. Please refer to the actual product for the appearance. To obtain the latest function introduction and safe usage guidelines, please visit the GOWOW official website to view the electronic manual.